

NEW

CA series

End Suction Volute Pumps OH-1



CAL

CAR

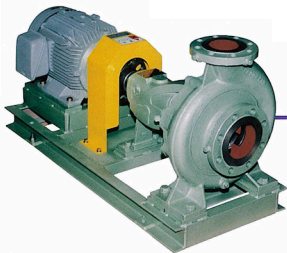

The TORISHIMA Eco

The CA is a high efficiency pump which has been created from our historical technology.
The CA is an Eco Pump which can save the energy and reduce CO₂.

Saving energy

<High efficiency pump contributes to saving energy and CO₂ reduction.>

◆ Reduction of LCC (Life Cycle Cost)

The main component of LCC is an Electrical Cost which is occupying approx. 70% to 90% as shown in figure.

Thus, you can reduce your LCC Cost by saving energy greatly.

■ Pumps : CAL Size 32 to 150
■ Pump operating conditions : 60Hz-4P, Clean Water(Normal Temp.)

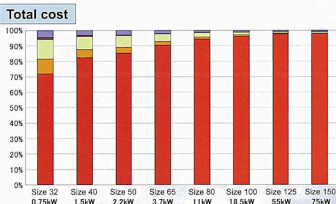

Initial cost **Running cost**

- Pump
- Labor charge
- Electricity cost
- Labor charge
- Parts

◆ Reduction of CO₂

Saving energy means CO₂ reduction.

<Example>

7m³ / min at 40m
60Hz — 4pole

Selection result	High Efficiency Pump CAL	General pump
Pump efficiency	77%	73%
Power consumption	59kW	70kW
Annual electricity power consumption	516,840kWh	613,200kWh
Annual power consumption cost	¥5,168,400	¥6,377,280

Electricity bill : ¥10 / kWh

Amount of reduction of annual electricity power consumption
96,360kWh
(=613,200-516,840)

Annual amount of CO₂ reduction
32,600kg-CO₂
(=96,360×0.338※)

Annual amount of CO₂ reduction is 32,600kg-CO₂ and that is equal to amount of CO₂ emission to make a round trip between Tokyo and Osaka about 120 times by car (Mileage : 10km / 1 ♂ Gasoline).

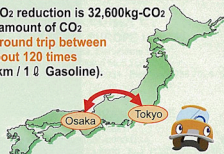

※ "0.338" is the coefficient of CO₂ emitting amount by the 2007's data of the Kansai Electric Power Co., Inc.: Amount of CO₂ emission indicated by "Kg" in generating 1 kWh electricity.

pump "CA series" leads the world!

Saving resources

◆ Speed-up, Simplification

Speed-up and miniaturizing make the pump simplify, then that makes it available to reduce the resources (material cost) and space to install.

◆ Low NPSH performance and wide application range

Low NPSH performance made it available to reduce the rate of cavitations occurring, then the suction water level can be set lower than before and that means the cost of plant construction can be cut down. CA pumps can deal with the various kinds of fluids, for example from -40°C to $+220^{\circ}\text{C}$ liquids, and various qualities.

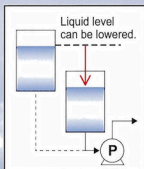

Saving power

◆ Simply designed Mechanical seal

Maintenance-free mechanical seal restrains liquid leakage at the shaft sealing. Also, it keeps the environment around the pump clean and saves the cost for treatment of leaked liquid.

◆ Non-shaft sleeve

The TORISHIMA rubber bellows mechanical seal, a standard type, is easy to set up and harmless to a shaft.

◆ Safe operation by the high precision design of bearing

◆ Stable operation

Due to the stable characteristic curve, operational abilities of valve control and parallel operation are excellent.

◆ In addition, trimming of impeller diameter results in saving energy

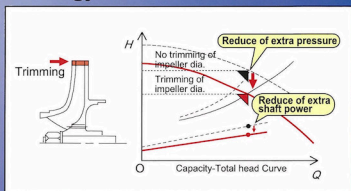

High-tech design

Both CAL and CAR are basically the same design to improve the interchangeability of parts.
However, CAR made of stainless steel is not fitted with wear rings.

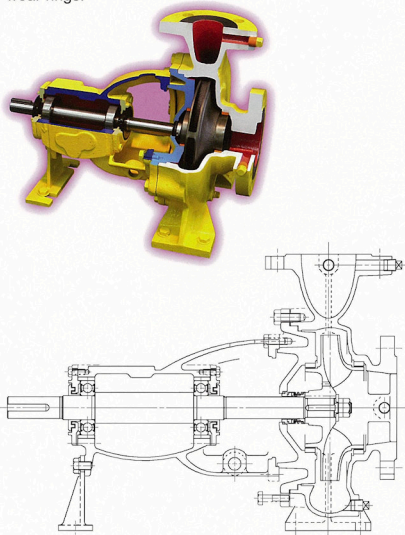

Interchangeability







Parts	Wear ring for Casing cover	Bearing case	Shaft	Mechanical seal
32-125	Red	Red	Red	Red
40-125				
65-125				
32-160				
40-160				
50-160	Blue	Red	Red	Red
65-150				
32-200				
40-200				
50-200				
65-190	Orange	Blue	Blue	Blue
80-150				
80-160				
80-190				
100-190				
80-200	Green	Blue	Blue	Blue
32-250				
40-250				
50-250				
65-240				
80-240	Pink	Blue	Blue	Blue
100-245				
80-250				
50-315				
65-310				
80-310	Light Blue	Orange	Orange	Orange
100-310				
150-200				
125-250				
200-250				
125-315	Grey	Green	Green	Green
80-400				
100-400				
125-400				
150-315				
150-400	Light Green	Pink	Pink	Green

*1. The same color within each parts indicates identical.
*2. The table indicates the case of 4p-electric motor drive specification.

Standard Specification

		CAL (Cast iron fitted)	CAR (Stainless steel fitted)
Liquid handled	Kind	Clean water, Water, Chemical medicine, Alkaline liquid, Brine, Heat transfer media, Abrasive slurry liquid (under 3wt%)	Pure water, Hot water, Sea water, Brine, Refrigerative media, Electrodeposition paint, Abrasive slurry liquid (under 3wt%)
	Temperature	-10°C~+80°C (220°C : Heat transfer media)	-10°C~+80°C (140°C : Water cooling of shaft seal)
Max. discharge pressure		1MPa (10kgf/cm ² G)	
Max. Suction pressure		0.5MPa (5kgf/cm ² G)	
Design	Impeller	Closed	
	Shaft seal	Single mechanical seal (Bellows type)	
	Flushing of shaft seal	Internal flushing	
	Lubrication of bearing	Grease lubrication	
Flange standard, Directions		JIS 10kgf/cm ² G.R.F., End-top	
Pump material	Casing	Cast iron	304 Stainless steel
	Impeller	Cast iron	304 Stainless steel
	Shaft	13%Cr Stainless steel	304 Stainless steel
	Casing wear ring	Cast iron	

Application

Utility		Co-generation, Air Conditioning system, Waste water treatment, Pure water manufacturing
Iron & Metal Manufacturing		Power generation plant, Rolling plant, Desulfurization plant, Roll coolant plant, Plating plant
Food Industries		Manufacturing process, Refrigeration system, CIP system
Car Industries (Painting Plant)		Degreasing process, Transformation process, Electrodeposition process
Garbage incinerating plant		Power generation equipment, Equipment lowering the temperature of high temperature waste gas
Other liquid handled		Brine, Acetone, Chlorization calcium, Potassium Chloride, Alkali liquid, Ethylene glycol, Nitric acid, Sulfuric acid, Sodium hydroxide, Sal volatile, Ammonium solution

Mechanical seals - maintenance free

◆ Selection chart of Shaft seals

Shaft seals	Application range (°C)		Materials	Water injection option	Examples of application liquid
	100°C or less in boiling point under normal pressure	100°C or more boiling point under normal pressure			
Rubber bellows mechanical seal (standard)	$-10 \leq t \leq 80$	$-10 \leq t \leq 80$	SiC×Carbon, NBR70	·Flushing (Internal)	Water, Oil
Multi-spring type mechanical seal	(non water cooling) $-10 \leq t < 80$ (water cooling) $80 \leq t \leq 160$	(non water cooling) $-10 \leq t < 100$ (water cooling) $100 \leq t \leq 220$	SiC×Carbon, FKM or EPR	·Flushing (Internal) ·Quenching ·Cooling	Water, Oil, Alkali, Refrigerant
Clutch type rubber bellows mechanical seal	(Single) $-10 \leq t < 80$ (Double) $-10 \leq t \leq 140$	(Single) $-10 \leq t < 100$ (Double) $-10 \leq t \leq 140$	Tungsten carbide×Tungsten carbide FKM or ERP	·Flushing (Internal, Self) ·Cooling	Water, Oil, Alkali, Electrodeposition paints

* NBR70 (Nitrile rubber), FKM (Fluoric rubber), and EPR (Ethylene propylene rubber) are packing materials.

* In case of liquids such as adhering after getting air or occurring toxic gases, please adopt double or quenching type mechanical seal.

* In case of water cooling type, pour the clean water (unusable of erosive liquid like seawater) and the temperature should be kept under 30°C.

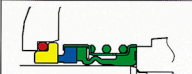
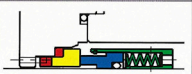
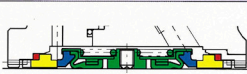
Rubber bellows type (as standard)	Multi-spring type	Clutch type rubber bellows
		

CAL (cast iron fitted) Selection Charts

50Hz-2P (3000min⁻¹)

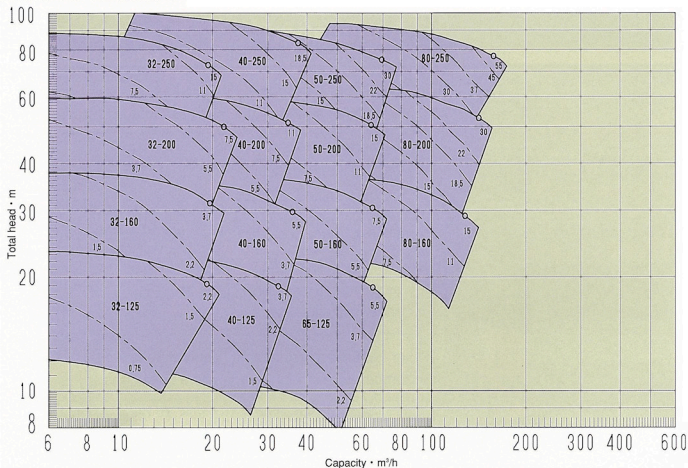

50Hz-4P (1500min⁻¹)

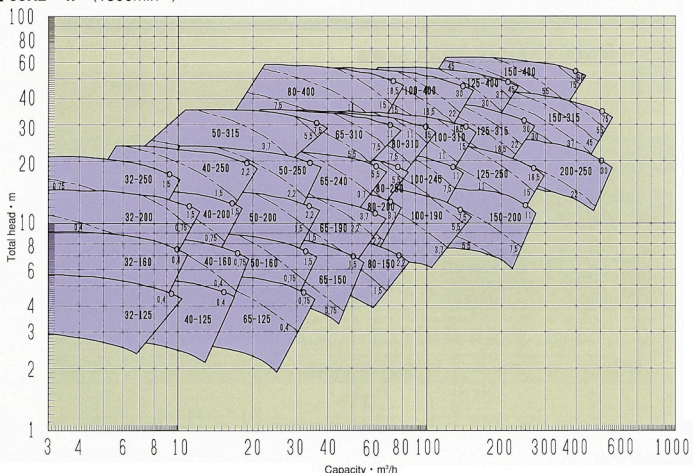

■ 60Hz—2P (3600min⁻¹)

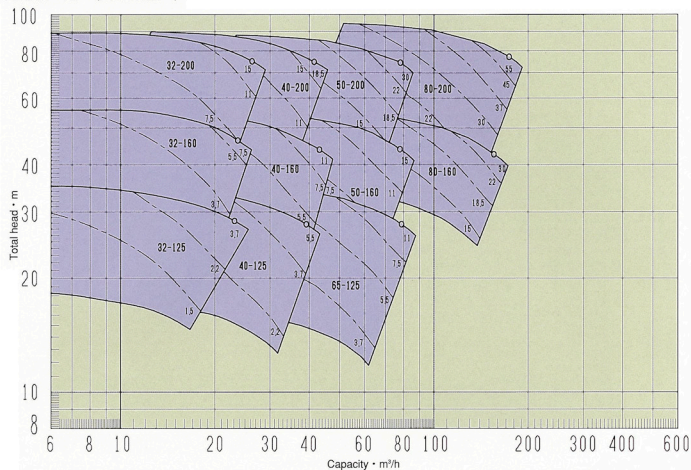

■ 60Hz—4P (1800min⁻¹)

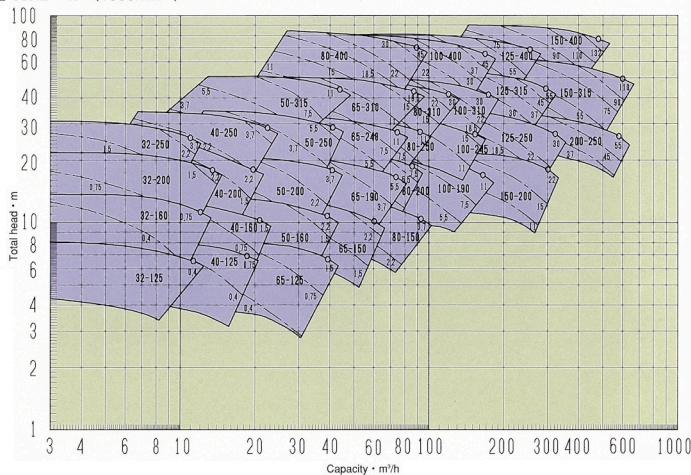

CAR (stainless steel fitted) Selection Charts

50Hz-2P (3000min⁻¹)

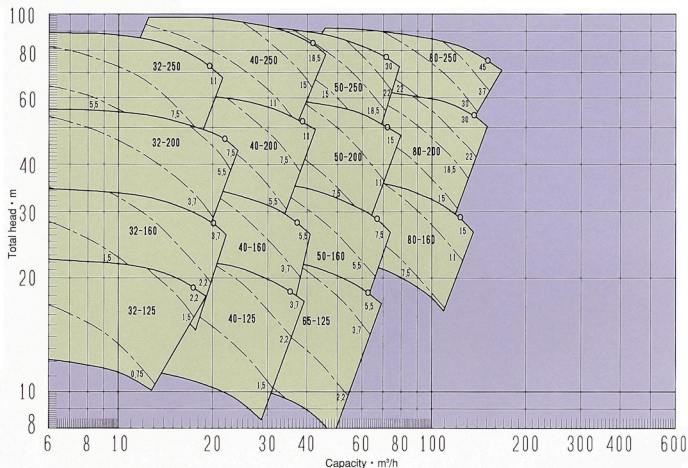

50Hz-4P (1500min⁻¹)

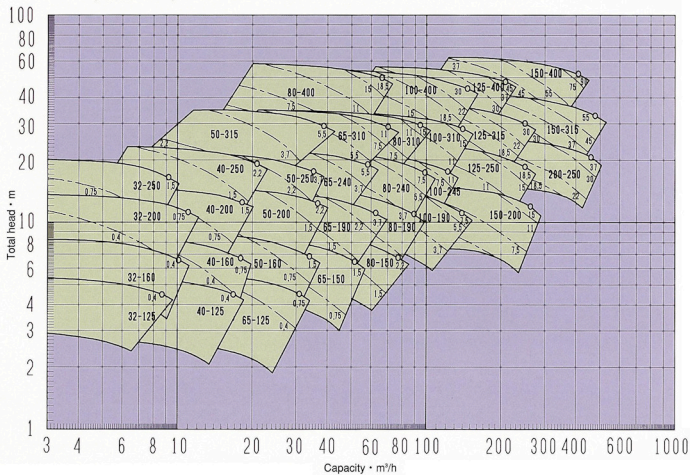

■ 60Hz-2P (3600min⁻¹)

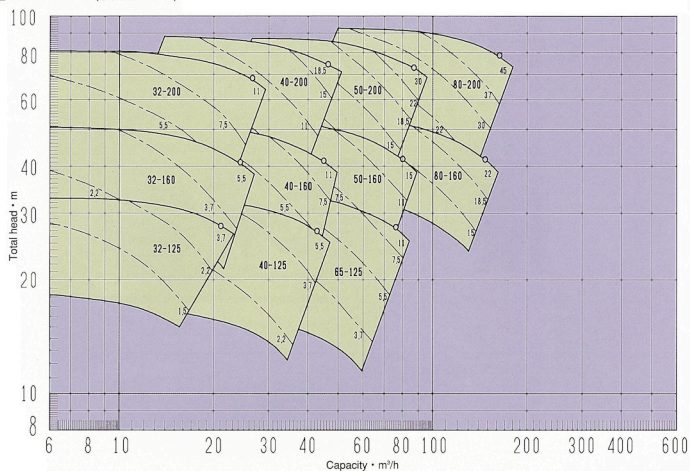

■ 60Hz-4P (1800min⁻¹)

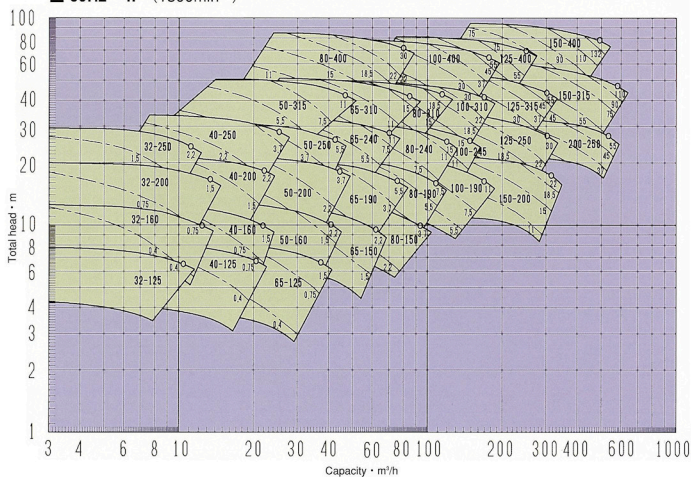

Dimension Charts

Flanges according to JIS 10K
 ASME, BS, and ISO also available

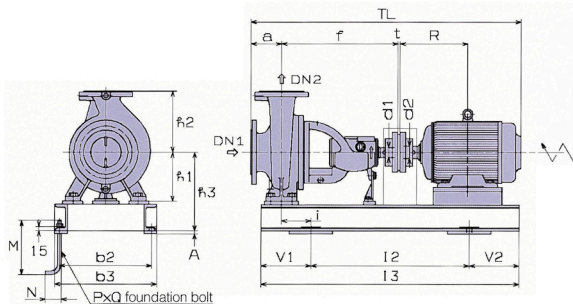

◆ Driver - 2 Pole Motor

(Unit:mm)

Pump sizes	Pump dimensions							Motor dimensions				Baseplate dimensions				Foundation dimensions							Coupling		TL							
	DN1	DN2	a	f	h1	h2	d1	Frame	R	d2	Totally enclosed fan-cooled type		h3	I3	A	Vt. (kgf)	h3	I	b2	I2'	M	N	P	Q		V1	V2	t	Vt. (kgf)			
											Output (kW)	Vt. (kgf)																		b3	Output (kW)	Vt. (kgf)
32-125 40-125	50 65	32 40	80 80	360 360	112 112	140 140	24 24	25 26	26 27	80	140	19	0.75	20	320	670	0	27	202	45	290	420	---	200	50	4	M12	105	145	3	1.1	725.5
										90S	156	24	1.5	23	320	750	0	28	202	55	290	480	---	200	50	4	M12	115	155	3	1.1	747.5
										90L	168.5	24	2.2	27	320	750	0	28	202	55	290	480	---	200	50	4	M12	115	155	3	1.1	775.5
										112M	200	28	3.7	45	320	750	0	27	202	55	290	480	---	200	50	4	M12	115	155	3	1.6	834.5
										132S	239	38	5.5	68	350	870	0	32	219	90	320	600	---	200	50	4	M12	150	120	3	3.2	897
										160M	323	42	11	128	430	1000	0	43	250	110	400	660	---	200	50	4	M12	170	170	3	6.7	1051
32-160 40-160	65	32 40	80 80	360 360	132 132	160 160	24 24	26 28	28 29	90S	156	24	1.5	23	320	750	0	30	222	55	290	480	---	200	50	4	M12	115	155	3	1.1	747.5
										90L	168.5	24	2.2	27	320	750	0	30	222	55	290	480	---	200	50	4	M12	115	155	3	1.1	775.5
										112M	200	28	3.7	45	320	750	0	28	222	55	290	480	---	200	50	4	M12	115	155	3	1.6	834.5
										132S	239	38	5.5	68	350	870	0	31	222	90	320	600	---	200	50	4	M12	150	120	3	3.2	897
										160M	323	42	11	128	430	1000	0	41	250	110	400	660	---	200	50	4	M12	170	170	3	6.7	1051
										160L	345	42	18.5	151	430	1000	0	41	250	110	400	660	---	200	50	4	M12	170	170	3	6.7	1095
65-125	80	65	100	360	132	180	24	28	29	180MA	351.5	48	22	190	430	1000	0	43	270	110	400	660	---	200	50	4	M12	170	170	3	9.0	1115
										90S	156	24	1.5	23	320	750	0	30	222	55	290	480	---	200	50	4	M12	115	155	3	1.1	767.5
										90L	168.5	24	2.2	27	320	750	0	30	222	55	290	480	---	200	50	4	M12	115	155	3	1.1	795.5
										112M	200	28	3.7	45	320	750	0	28	222	55	290	480	---	200	50	4	M12	115	155	3	1.6	854.5
										132S	239	38	5.5	68	350	870	0	31	222	90	320	600	---	200	50	4	M12	150	120	3	3.2	917
										160M	323	42	11	128	430	1000	0	41	250	110	400	660	---	200	50	4	M12	170	170	3	6.7	1071

(Unit:mm)

Pump sizes	Pump dimensions							Motor dimensions				Baseplate dimensions				Foundation dimensions								Coupling		TL										
	DN1	DN2	a	f	h1	h2	d1	Wt. (kgF)	Frame	R	d2	Output (kW)	Totally enclosed fan-cooled type	Wt. (kgF)	h3	i	A	Wt. (kgF)	h3	i	b2	I2	I2'	M	N		P	Q	V1	V2	Wt. (kgF)	TL				
																																	CAL	CAR		
32-200 40-200	50	32	40	80	360	160	180	24	34	37	34	37	112M	200	28	3.7	45	320	750	0	32	250	85	290	480	---	200	50	4	M12	115	155	3	1.6	834.5	
													132S	239	38	5.5	7.5	68	350	870	0	34	250	90	320	600	---	200	50	4	M12	150	120	3	3.2	897
													160M	323	42	11	15	128	430	1000	0	39	250	110	400	660	---	200	50	4	M12	170	170	3	6.7	1051
													160L	345	42	18.5	151	430	1000	0	39	250	110	400	660	---	200	50	4	M12	170	170	3	6.7	1095	
50-160	80	50	100	360	160	180	24	30	31	112M	200	28	3.7	45	320	750	0	32	250	85	290	480	---	200	50	4	M12	115	155	3	1.6	854.5				
										132S	239	38	5.5	7.5	68	350	870	0	34	250	90	320	600	---	200	50	4	M12	150	120	3	3.2	917			
										160M	323	42	11	15	128	430	1000	0	39	250	110	400	660	---	200	50	4	M12	170	170	3	6.7	1071			
										160L	345	42	18.5	151	430	1000	0	39	250	110	400	660	---	200	50	4	M12	170	170	3	6.7	1115				
50-200	80	50	100	360	160	200	24	35	37	112M	200	28	3.7	45	320	750	0	32	250	85	290	480	---	200	50	4	M12	115	155	3	1.6	854.5				
										132S	239	38	5.5	7.5	68	350	870	0	34	250	90	320	600	---	200	50	4	M12	150	120	3	3.2	917			
										160M	323	42	11	15	128	430	1000	0	39	250	110	400	660	---	200	50	4	M12	170	170	3	6.7	1071			
										160L	345	42	18.5	151	430	1000	0	39	250	110	400	660	---	200	50	4	M12	170	170	3	6.7	1115				
80-160	100	80	125	470	160	225	32	47	50	180MA	351.5	48	22	190	430	1000	0	42	270	110	400	660	---	200	50	4	M12	170	170	3	9.0	1135				
										200LA	395.5	55	30	37	300	470	1120	0	53	292	130	440	740	---	300	50	4	M12	190	190	3	13.9	1233			
										112M	200	28	3.7	45	380	870	0	32	270	75	350	600	---	200	50	4	M12	150	120	3	3.2	964.5				
										132S	239	38	5.5	7.5	68	430	1000	0	42	270	95	400	660	---	200	50	4	M12	170	170	3	3.2	1027			
32-250 40-250 50-250	50	32	40	100	470	180	225	32	47	52	57	60	160M	323	42	11	15	128	470	1120	0	45	270	115	440	740	---	200	50	4	M12	190	190	3	6.7	1181
													160L	345	42	18.5	151	470	1120	0	45	270	115	440	740	---	200	50	4	M12	190	190	3	6.7	1225	
													180MA	351.5	48	22	190	470	1120	0	43	270	115	440	740	---	200	50	4	M12	190	190	3	9.0	1245	
													200LA	395.5	55	30	37	300	530	1250	10	67	317	130	490	840	---	250	63	4	M16	205	205	3	13.9	1343
80-200	100	80	125	470	180	250	32	54	56	112M	200	28	3.7	45	380	870	0	32	270	75	350	600	---	200	50	4	M12	150	120	3	3.2	989.5				
										132S	239	38	5.5	7.5	68	430	1000	0	42	270	95	400	660	---	200	50	4	M12	170	170	3	3.2	1052			
										160M	323	42	11	15	128	470	1120	0	45	270	115	440	740	---	200	50	4	M12	190	190	3	6.7	1206			
										160L	345	42	18.5	151	470	1120	0	45	270	115	440	740	---	200	50	4	M12	190	190	3	6.7	1250				
80-250	100	80	125	470	225	280	32	74	80	180MA	351.5	48	22	190	470	1120	0	43	270	115	440	740	---	200	50	4	M12	190	190	3	9.0	1270				
										200LA	395.5	55	30	37	300	530	1250	10	67	317	130	490	840	---	250	63	4	M16	205	205	3	13.9	1368			
										225MA	414.5	55	45	350	530	1250	10	69	342	130	490	840	---	250	63	4	M16	205	205	3	13.9	1409				
										250SA	463.5	60	55	470	530	1250	10	76	370	130	490	840	---	250	63	4	M16	205	205	4	21.0	1481.5				
80-250	100	80	125	470	225	280	32	74	80	250MA	482.5	60	75	640	530	1250	10	76	370	130	490	840	---	250	63	4	M16	205	205	4	21.0	1519.5				
										160M	323	42	11	15	128	470	1120	0	52	317	100	440	740	---	200	50	4	M12	190	190	3	6.7	1206			
										160L	345	42	18.5	151	470	1120	0	52	317	100	440	740	---	200	50	4	M12	190	190	3	6.7	1250				
										180MA	351.5	48	22	190	470	1120	0	53	317	100	440	740	---	200	50	4	M12	190	190	3	9.0	1270				
80-250	100	80	125	470	225	280	32	74	80	200LA	395.5	55	30	37	300	530	1250	10	74	342	115	490	840	---	250	63	4	M16	205	205	3	13.9	1368			
										225MA	414.5	55	45	350	530	1250	10	65	342	115	490	840	---	250	63	4	M16	205	205	3	13.9	1409				
										250SA	463.5	60	55	470	530	1250	10	74	370	115	490	840	---	250	63	4	M16	205	205	4	21.0	1481.5				
										250MA	482.5	60	75	640	530	1250	10	74	370	115	490	840	---	250	63	4	M16	205	205	4	21.0	1519.5				

Driver - 4 Pole Motor

(Unit:mm)

Pump sizes	Pump dimensions						Motor dimensions				Baseplate dimensions				Foundation dimensions								Coupling		TL								
	DN1	DN2	a	f	h1	h2	d1	Wt. (kgf)	Frame	R	d2	Totally enclosed fan cooled type		T3	T4	Wt. (kgf)	h3	i	b2	I2	I2'	M	N	P		Q	V1	V2	t	Wt. (kgf)			
												Output (kW)	Wt. (kgf)																		CA	CAR	
32-155 40-125	50	32	80	360	112	140	24	25	26	27	80	140	19	0.75	20	320	670	0	27	202	45	290	420	---	200	50	4	M12	105	145	3	1.1	725.5
	65	40	80	360	112	140	24	26	27	80	140	19	0.75	20	320	670	0	28	222	45	290	420	---	200	50	4	M12	105	145	3	1.1	725.5	
32-160 40-160	50	32	80	360	132	160	24	26	28	29	90L	168.5	24	1.5	27	320	750	0	30	222	55	290	480	---	200	50	4	M12	115	155	3	1.1	775.5
	65	40	80	360	132	160	24	28	29	90L	168.5	24	1.5	27	320	750	0	28	222	45	290	420	---	200	50	4	M12	105	145	3	1.1	745.5	
65-125	80	65	100	360	132	180	24	28	29	90L	168.5	24	1.5	27	320	750	0	30	222	55	290	480	---	200	50	4	M12	115	155	3	1.1	795.5	
	100	80	100	360	132	180	24	28	29	90L	168.5	24	1.5	27	320	750	0	28	222	45	290	420	---	200	50	4	M12	105	145	3	1.1	725.5	
32-200 40-200	50	32	80	360	160	180	24	34	37	90L	168.5	24	1.5	27	320	750	0	33	250	55	290	480	---	200	50	4	M12	115	155	3	1.1	775.5	
	65	40	80	360	160	180	24	35	37	100L	193	28	2.2	37	320	750	0	33	250	55	290	480	---	200	50	4	M12	115	155	3	1.6	817.5	
50-160 65-150	80	50	100	360	160	180	24	30	31	112M	200	28	3.7	45	320	750	0	32	250	55	290	480	---	200	50	4	M12	115	155	3	1.9	834.5	
	80	65	100	360	160	180	24	32	35	80	140	19	0.75	20	320	670	0	30	250	45	290	420	---	200	50	4	M12	105	145	3	1.1	745.5	
50-200 65-190	80	50	100	360	160	200	24	35	37	90L	168.5	24	1.5	27	320	750	0	33	250	55	290	480	---	200	50	4	M12	115	155	3	1.1	795.5	
	80	65	100	360	160	200	24	39	42	100L	193	28	2.2	37	320	750	0	33	250	55	290	480	---	200	50	4	M12	115	155	3	1.6	837.5	
80-160	100	80	100	470	160	200	32	44	46	112M	200	28	3.7	45	320	870	0	29	250	90	290	600	---	200	50	4	M12	150	120	3	3.2	947.5	
	100	80	100	470	160	200	32	44	46	112M	200	28	3.7	45	320	870	0	36	270	75	350	600	---	200	50	4	M12	150	120	3	3.2	947.5	
32-250 40-250	50	32	100	470	180	225	32	47	51	90L	168.5	24	1.5	27	380	870	0	36	270	75	350	600	---	200	50	4	M12	150	120	3	3.2	947.5	
	65	40	100	470	180	225	32	52	55	112M	200	28	3.7	45	380	870	0	32	270	75	350	600	---	200	50	4	M12	150	120	3	3.2	947.5	
65-240 80-190	80	65	100	470	180	225	32	56	60	132S	239	38	5.5	68	430	1000	0	42	270	95	400	660	---	200	50	4	M12	170	170	3	3.2	1027	
	100	80	100	470	180	225	32	49	52	132S	239	38	5.5	68	430	1000	0	42	270	95	400	660	---	200	50	4	M12	170	170	3	3.2	1065	
80-200	100	80	125	470	180	250	32	53	57	160M	323	42	11	128	470	1120	0	45	270	115	440	740	---	200	50	4	M12	190	190	3	6.7	1181	
	100	80	125	470	180	250	32	53	57	80	140	19	0.75	20	380	870	0	36	270	75	350	600	---	200	50	4	M12	150	120	3	3.2	880.5	
80-240	100	80	100	470	200	250	32	62	66	90L	168.5	24	1.5	27	380	870	0	36	270	75	350	600	---	200	50	4	M12	150	120	3	3.2	930.5	
	100	80	100	470	200	250	32	62	66	100L	193	28	2.2	37	380	870	0	38	270	75	350	600	---	200	50	4	M12	150	120	3	3.2	972.5	
100-190	125	100	125	470	200	280	32	61	64	112M	200	28	3.7	45	380	870	0	32	270	75	350	600	---	200	50	4	M12	150	120	3	3.2	989.5	
	125	100	125	470	200	280	32	61	64	132S	239	38	5.5	68	430	1000	0	46	292	90	400	660	---	200	50	4	M12	170	170	3	3.2	1052	
80-250 100-245 65-310 80-310	100	80	125	470	225	280	32	73	77	132M	258	38	7.5	77	430	1000	0	46	292	90	400	660	---	200	50	4	M12	170	170	3	3.2	1052	
	100	80	125	470	225	280	32	72	77	160M	323	42	11	128	470	1120	0	49	292	100	440	740	---	200	50	4	M12	190	190	3	6.7	1206	
80-250 100-245 65-310 80-310	100	80	125	470	225	280	32	73	77	160L	345	42	15	151	470	1120	0	49	292	100	440	740	---	200	50	4	M12	190	190	3	6.7	1228	
	100	80	125	470	225	280	32	70	75	112M	200	28	3.7	45	430	870	0	45	317	60	400	600	---	200	50	4	M12	150	120	3	3.2	989.5	
80-250 100-245 65-310 80-310	100	80	125	470	225	280	32	73	77	132S	239	38	5.5	68	430	1000	0	49	317	80	400	660	---	200	50	4	M12	170	170	3	3.2	1052	
	100	80	125	470	225	280	32	72	77	132M	258	38	7.5	77	430	1000	0	49	317	80	400	660	---	200	50	4	M12	170	170	3	3.2	1027	
80-250 100-245 65-310 80-310	100	80	125	470	225	280	32	72	77	160M	323	42	11	128	470	1120	0	52	317	100	440	740	---	200	50	4	M12	190	190	3	6.7	1206	
	100	80	125	470	225	280	32	70	75	160L	345	42	15	151	470	1120	0	52	317	100	440	740	---	200	50	4	M12	190	190	3	6.7	1228	
80-250 100-245 65-310 80-310	100	80	125	470	225	280	32	73	77	180M	351.5	48	18.5	190	470	1120	0	53	317	100	440	740	---	200	50	4	M12	190	190	3	9.0	1270	
	100	80	125	470	225	280	32	72	77	190L	370.5	48	22	205	470	1120	0	53	317	100	440	740	---	200	50	4	M12	190	190	3	9.0	1308	
80-250 100-245 65-310 80-310	100	80	125	470	225	280	32	73	77	200L	396.5	55	30	300	530	1250	10	74	342	115	490	840	---	250	63	4	M16	205	205	3	13.9	1368	

(Unit:mm)

Pump sizes	Pump dimensions							Motor dimensions				Baseplate dimensions			Foundation dimensions								Coupling		TL									
	DN1	DN2	a	f	h1	h2	d1	Wt. (kgf)	Frame	R	d2	Totally enclosed Fan-cooled type		h3	I3	A	Wt. (kgf)	h3	l	l2	l2'	M	N	P		Q	V1	V2	Wt. (kgf)					
												Output (kW)	Wt. (kgf)																	b3	13	4		
CAL	CAR																																	
100-310	128	100	125	470	250	315	32	79	83	132M	258	38	7.5	77	430	1000	0	51	342	80	400	660	---	200	50	4	M12	170	170	3	3.2	1090		
										160M	323	42	11	128	470	1120	0	56	342	100	440	740	---	200	50	4	M12	190	190	3	6.7	1206		
										160L	345	42	15	151	470	1120	0	56	342	100	440	740	---	200	50	4	M12	190	190	3	6.7	1228		
										180M	351.5	48	18.5	190	470	1120	0	56	342	100	440	740	---	200	50	4	M12	190	190	3	9.0	1270		
										180LC	370.5	48	22	205	470	1120	0	56	342	100	440	740	---	200	50	4	M12	190	190	3	9.0	1308		
										200LC	395.5	55	30	300	530	1250	10	75	367	115	490	840	---	250	63	4	M16	205	205	3	13.9	1368		
										225SC	432	60	37	355	530	1250	10	75	367	115	490	840	---	250	63	4	M16	205	205	4	21.0	1415		
										225SC	432	60	37	355	530	1250	10	75	367	115	490	840	---	250	63	4	M16	205	205	3	13.9	1368		
150-200 125-250	150	125	140	470	250	315	355	42	78	84	97	132S	239	38	5.5	68	430	1000	0	51	342	80	500	660	---	200	50	4	M12	170	170	3	5.4	1067
												132M	258	38	7.5	77	430	1000	0	51	342	80	500	660	---	200	50	4	M12	170	170	3	5.4	1105
												160M	323	42	11	128	470	1120	0	56	342	100	440	740	---	200	50	4	M12	190	190	3	6.7	1221
												180L	345	42	15	151	470	1120	0	56	342	100	440	740	---	200	50	4	M12	190	190	3	6.7	1243
												180M	351.5	48	18.5	190	470	1120	0	56	342	100	440	740	---	200	50	4	M12	190	190	3	9.0	1285
												180LC	370.5	48	22	205	470	1120	0	56	342	100	440	740	---	200	50	4	M12	190	190	3	9.0	1323
												200LC	395.5	55	30	300	530	1250	10	75	367	115	490	840	---	250	63	4	M16	205	205	3	13.9	1383
												225SC	432	60	37	355	530	1250	10	75	367	115	490	840	---	250	63	4	M16	205	205	4	21.0	1430
80-400	100	80	125	470	280	355	42	116	125	132M	258	38	7.5	77	510	1000	0	58	372	80	480	660	---	200	50	4	M12	170	170	3	5.4	1090		
										160M	323	42	11	128	530	1250	10	77	397	115	490	840	---	250	63	4	M16	205	205	3	6.7	1206		
										160L	345	42	15	151	530	1250	10	77	397	115	490	840	---	250	63	4	M16	205	205	3	6.7	1228		
										180M	351.5	48	18.5	190	530	1250	10	77	397	115	490	840	---	250	63	4	M16	205	205	3	9.0	1270		
										180LC	370.5	48	22	205	530	1250	10	77	397	115	490	840	---	250	63	4	M16	205	205	3	9.0	1308		
										200LC	395.5	55	30	300	590	1400	10	89	397	140	550	940	---	250	63	4	M16	230	230	3	13.9	1368		
										225SC	432	60	37	355	590	1400	10	92	397	140	550	940	---	250	63	4	M16	230	230	4	21.0	1415		
										225M	444.5	60	45	365	590	1400	10	92	397	140	550	940	---	250	63	4	M16	230	230	4	21.0	1440		
125-315 100-400	150	125	140	530	280	355	42	134	147	160L	345	42	15	151	530	1250	10	81	400	95	490	840	---	250	63	4	M16	205	205	3	6.7	1303		
										180M	351.5	48	18.5	190	530	1250	10	80	400	95	490	840	---	250	63	4	M16	205	205	3	9.0	1345		
										180LC	370.5	48	22	205	530	1250	10	80	400	95	490	840	---	250	63	4	M16	205	205	3	9.0	1383		
										200LC	395.5	55	30	300	590	1400	10	91	400	120	550	940	---	250	63	4	M16	230	230	3	13.9	1443		
										225SC	432	60	37	355	590	1400	10	87	400	120	550	940	---	250	63	4	M16	230	230	4	21.0	1490		
										225M	444.5	60	45	365	590	1400	10	87	400	120	550	940	---	250	63	4	M16	230	230	4	21.0	1515		
										250M	463.5	70	55	510	640	1400	10	87	400	120	550	940	---	250	63	4	M16	230	230	4	31.0	1556.5		
										250M	482.5	70	75	570	640	1400	10	87	400	120	550	940	---	250	63	4	M16	230	230	4	31.0	1594.5		
125-400	150	125	140	530	315	400	42	153	163	160L	345	42	15	151	590	1250	10	90	435	95	550	840	---	250	63	4	M16	205	205	3	6.7	1303		
										180M	351.5	48	18.5	190	590	1250	10	90	435	95	550	840	---	250	63	4	M16	205	205	3	9.0	1345		
										180LC	370.5	48	22	205	590	1250	10	90	435	95	550	840	---	250	63	4	M16	205	205	3	9.0	1383		
										200LC	395.5	55	30	300	590	1400	10	99	435	120	550	940	---	250	63	4	M16	230	230	3	13.9	1443		
										225SC	432	60	37	355	590	1400	10	95	435	120	550	940	---	250	63	4	M16	230	230	4	21.0	1490		
										225M	444.5	60	45	365	590	1400	10	95	435	120	550	940	---	250	63	4	M16	230	230	4	21.0	1515		
										250SC	463.5	70	55	510	640	1400	10	99	435	120	600	940	---	250	63	4	M16	230	230	4	31.0	1556.5		
										250M	482.5	70	75	570	640	1400	10	99	435	120	600	940	---	250	63	4	M16	230	230	4	31.0	1594.5		
200-250	200	200	160	530	315	375	42	129	137	280SB	544	80	90	700	710	1600	10	109	435	160	670	1060	---	250	63	4	M16	270	270	4	45.0	1745.5		
										160L	345	42	15	151	590	1250	10	90	435	95	550	840	---	250	63	4	M16	205	205	3	6.7	1323		
										180M	351.5	48	18.5	190	590	1250	10	90	435	95	550	840	---	250	63	4	M16	205	205	3	9.0	1365		
										180LC	370.5	48	22	205	590	1250	10	90	435	95	550	840	---	250	63	4	M16	205	205	3	9.0	1403		
										200LC	395.5	55	30	300	590	1400	10	99	435	120	550	940	---	250	63	4	M16	230	230	3	13.9	1463		
										225SC	432	60	37	355	590	1400	10	95	435	120	550	940	---	250	63	4	M16	230	230	4	21.0	1510		
										225M	444.5	60	45	365	590	1400	10	95	435	120	550	940	---	250	63	4	M16	230	230	4	21.0	1535		
										250SC	463.5	70	55	510	640	1400	10	99	435	120	600	940	---	250	63	4	M16	230	230	4	31.0	1576.5		
150-315 150-400	200	150	160	530	315	450	48	175	184	250M	482.5	70	75	570	640	1400	10	99	435	120	600	940	---	250	63	4	M16	230	230	4	31.0	1614.5		
										180LC	370.5	48	22	205	590	1250	10	90	435	95	550	840	---	250	63	4	M16	205	205	3	9.0	1403		
										200LC	395.5	55	30	300	590	1400	10	99	435	120	550	940	---	250	63	4	M16	230	230	3	13.9	1463		
										225SC	432	60	37	355	590	1400	10	95	435	120	550	940	---	250	63	4	M16	230	230	4	21.0	1510		
										225M	444.5	60	45	365	590	1400	10	95	435	120	5													

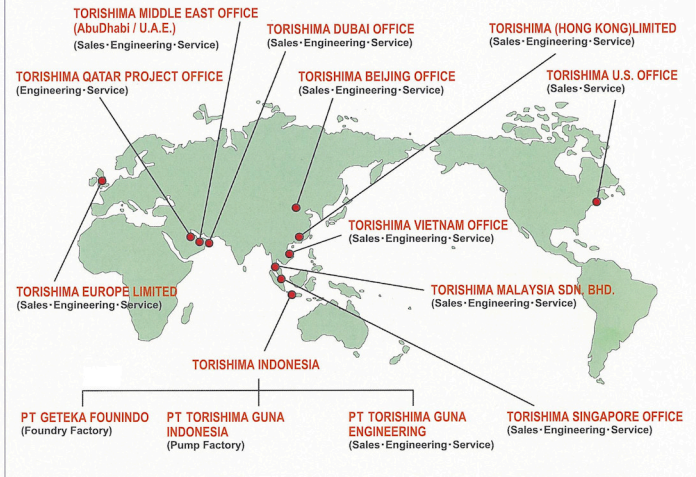

TORISHIMA PUMP MFG. CO., LTD.

Head Office & Works: 1-1-8, Miyata-cho, Takatsuki City, Osaka, Japan. Phone: 072-695-0551 Fax: 072-693-1288

TORISHIMA CHINA

BEIJING OFFICE

Rm707, Building 1, KUNSHA CENTER,
No.16 Xinyuanli, Chaoyang District, Beijing,
P.R. China PC: 100027
Phone: (86)10-8468-2891 Fax: (86)10-8468-2891

TORISHIMA HONG KONG

TORISHIMA (HONG KONG) LIMITED

Unit 605, 6/F., Tower II, Enterprise Square,
9 Sheung Yuet Road, Kowloon Bay,
Kowloon, Hong Kong
Phone: (852)2795-1838 Fax: (852)2754-3293

TORISHIMA VIETNAM

VIETNAM OFFICE

No.76 Bui Thi Xuan Street, Hai Ba Trung
District, Hanoi, Socialist Republic of Vietnam
Phone: (84)4-943-7880 Fax: (84)4-943-7876

TORISHIMA SINGAPORE

SINGAPORE OFFICE

30 Ubi Crescent #01-02 Ubi Techpark
Singapore 408566
Phone: (65)6779-0123 Fax: (65)6779-6900

TORISHIMA MALAYSIA

TORISHIMA MALAYSIA SDN. BHD

Suite 1906, 19th Floor Kenanga International
Jalan Sultan Ismail 50250 Kuala Lumpur,
Malaysia
Phone: (603)2715-0068 Fax: (603)2715-0019

TORISHIMA INDONESIA

PT TORISHIMA GUNA INDONESIA

Jalan Rawa Sumur Timur No.1,
Pulogadung Industrial Estate,
Jakarta 13930, Indonesia
Phone: (62)021-460-3963 Fax: (62)021-460-3937

PT TORISHIMA GUNA ENGINEERING

Jalan Rawa Sumur Timur No.1,
Pulogadung Industrial Estate,
Jakarta 13930, Indonesia
Phone: (62)021-460-3963 Fax: (62)021-460-3937

PT GETEKA FOUNINDO(Foundry Factory)

JL Pulo Ayang Kav. AA2
Pulogadung Industrial Estate,
Jakarta 13930, Indonesia
Phone: (62)021-460-3963 Fax: (62)021-460-3937

TORISHIMA U.A.E.

MIDDLE EAST OFFICE

5th Floor, office No.503, Al Salmeeen
Golden Tower, P.O Box: 53567,
Electra Street, Abu Dhabi, U.A.E.
Phone: (971)2-6743880 Fax: (971)2-6743881

DUBAI OFFICE

Office No.304 Building No.1979, Ahmed S.A Al
Amr Baesha Area, Dubai, United Arab Emirates
P.O Box: 283175, Dubai, U.A.E.
Phone: +971-(0)4-430-9404 Fax: +971-(0)4-430-9403

TORISHIMA QATAR

QATAR PROJECT OFFICE

Office No.11, 1st Floor, West Bay Corner
Building, Salwa Road, Doha, Qatar
Phone: (974)450-6915 Fax: (974)450-6916

TORISHIMA EUROPE

TORISHIMA EUROPE LIMITED

Sunnyside Works, Gartsherrie Rd
Coatbridge, Scotland ML5 2DL
Phone: (44)1236 443951 Fax: (44)1236 702875

TORISHIMA U.S.A.

NORTH AMERICAN OFFICE

100 Grove Street, Suite217,
Worcester MA01605-0000 USA
Phone: (1)508-753-6600 Fax: (1)508-753-8276